

JR072

Double Pendulum

Children's outdoor exercise equipment

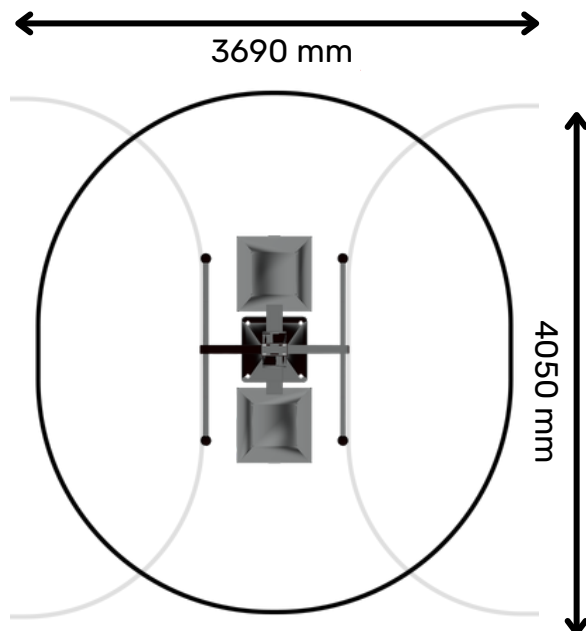

-  RAL7024
-  RAL5012
-  RAL6019
-  RAL2003
-  RAL3020

Movement area requirements
Movement spaces including areas of movement
may overlap.

Frame

- All steel frame construction - wall thickness 3 - 4 mm
- Hot dip galvanized and powder coated
- Maintenance-free stainless steel roller bearings
- Stainless steel / acid-resistant hardware
- Stainless steel footrests

Standard colors

- Moving parts - RAL7024 DARK GRAY
- Frame - See chart above - **All RAL-Classic colors**

Standard EN16630:2015, EN1176-1:2024-05

Target group children under 140 cm

Installation

- Concrete base, Ground Socket or Machine Platform
ATTENTION! Ground frost insulation required

Length

1050 mm

Width

690 mm

Height

960 mm

Required area

15,2 m²